

Oxygen – Analyser Series PMA[®]

PMA 10, PMA 10S portable

Instruction Manual
Version 1.00.02



Content

1	General information	5
2	Declaration of conformity	5
3	Safety instructions	6
4	Warranty	6
5	Used terms and signal indications	7
6	Introduction	8
6.1	Serial number	8
7	Application	8
8	Technical data	9
9	Description	10
9.1	Front panel	11
9.2	Gas flow diagram of the analyser PMA 10(S)	12
9.3	Options	12
9.3.1	Approval according to 13. and 17. BImSchV and TA-Luft (not for PMA 10S)	12
9.3.2	Output signal	12
9.3.3	Rechargeable battery	12
9.3.4	Sample gas pump	12
9.3.5	Alarm contact outlet (not for PMA 10S)	12
10	The measuring principle	13
11	Receipt of goods and storage	14
12	Installation	14
12.1	Connection of Sample gas inlet and sample gas outlet	15
13	Standard gas conditioning system	15
14	Electrical connection	16
14.1	Signal output	16
14.2	Option alarm contact output	16
14.2.1	Adjustment of the alarm threshold	17
15	Connections on the rear side	17
16	Starting up	18
16.1	Execution with rechargeable battery	18
17	Calibration	18
17.1	Zero calibration	19
17.1.1	Cross sensitivities	20
17.1.2	Consideration of cross sensitivities	21
17.2	Span calibration	22
18	Measuring	23
19	Closing down	24
20	Maintenance	24
20.1	Check and change of the internal filter element	24
21	Trouble shooting	25
22	Spare parts list	26
23	Appendix	26

List of Illustrations

Figure 1	Dimensions	10
Figure 2	Front panel.....	11
Figure 3	Gas flow diagram PMA 10(S).....	12
Figure 4	Scheme of the measuring cell and optical signal processing	13
Figure 5	Standard gas conditioning system	15
Figure 6	Plug connection signal output	16
Figure 7	Rear side	17
Figure 8	PMA 10(S) with open housing.....	25
Figure 9	Component buildup (Drawing-No.: 2355-5.01.0).....	27



Dear customer,

Thank you for buying our product. In this instruction manual you will find all necessary information about this M&C product. The information in the instruction manual is fast and easy to find, so you can start using your M&C product right after you have read the manual.

If you have any question regarding the product or the application, please don't hesitate to contact M&C or your M&C authorized distributor. You will find all the addresses in the appendix of this manual.

For additional information about our products and our company, please go to M&C's website www.mc-techgroup.com. There you will find the data sheets and manuals of all our products in German and English.

This Operating Manual does not claim completeness and may be subject to technical modifications.

© 01/2017 **M&C TechGroup** Germany GmbH. Reproduction of this document or its content is not allowed without permission from **M&C**.

PMA® is a registered trade mark.

Version: 1.00.02

HEAD OFFICE

M&C TechGroup Germany GmbH ♦ Rehhecke 79 ♦ 40885 Ratingen ♦ Germany

Telephone: 02102 / 935 – 0

Fax: 02102 / 935 – 111

E - mail: info@mc-techgroup.com

www.mc-techgroup.com

1 GENERAL INFORMATION

The product described in this manual has been built and tested in our production facility.

All M&C products are packed to be shipped safely. To ensure the safe operation and to maintain the safe condition, all instructions and regulations stated in this manual need to be followed. This manual includes all information regarding proper transportation, storage, installation, operation and maintenance of this product by qualified personnel.

Please follow all instructions and warnings closely.

Please read this manual carefully before commissioning and operating the device. If you have any questions regarding the product or the application, please don't hesitate to contact M&C or your M&C authorized distributor.

2 DECLARATION OF CONFORMITY



The product described in this operating manual complies with the following EU directives:

EMV-Instruction

The requirements of the EU directive 2014/30/EU “Electromagnetic compatibility” are met.

Low Voltage Directive

The requirement of the EU directive 2014/35/EU “Low Voltage Directive” are met.
The compliance with this EU directive has been examined according to DIN EN 61010.

Declaration of conformity

The EU Declaration of conformity can be downloaded from the **M&C** homepage or directly requested from **M&C**.



3 SAFETY INSTRUCTIONS

Follow these safety directions and instructions regarding installation, commissioning and operation of this device:

Read this manual before commissioning and operating the product. Please make sure to follow all safety instructions.

Installation and commissioning of electrical devices must be carried out only by qualified skilled personnel in compliance with the current regulations.

The installation and commissioning of the device must conform to the requirements of VDE 0100 (IEC 364) 'Regulations on the Installation of Power Circuits with Nominal Voltages below 1000 V' and must be in compliance with all relevant regulations and standards.

Before connecting the device, please make sure to compare the supply voltage with the specified voltage on the product label.

Protection against damages caused by high voltages:

Disconnect power supply before opening the device for access. Make sure that all external power supplies are disconnected.

Operate the device only in the permitted temperature and pressure ranges. For details please refer to the technical data sheet or manual.

Install the device only in protected areas, sheltered from rain and moisture. The product should not be exposed to the elements.

This device is NOT certified to be installed or operated in explosive hazardous areas.

Installation, maintenance, inspections and any repairs of the devices must be carried out only by qualified skilled personnel in compliance with the current regulations.

4 WARRANTY

In case of a device failure, please contact immediately M&C or your M&C authorized distributor.

We have a warranty period of 12 months from the delivery date. The warranty covers only appropriately used products and does not cover the consumable parts. Please find the complete warranty conditions in our terms and conditions.

The warranty includes a free-of-charge repair in our production facility or the free replacement of the device. If you return a device to M&C, please be sure that it is properly packaged and shipped with protective packaging. The repaired or replaced device will be shipped free of delivery charges to the point of use.

5 USED TERMS AND SIGNAL INDICATIONS



DANGER!

The 'Danger' warning sign indicates that death, serious injury and/or significant material damage will be the consequence, if the appropriate precautions should not be taken.



WARNING!

The 'Warning' warning sign indicates that death, serious injury or damage to property may occur if the relevant precautionary measures are not observed.



CAUTION!

The 'Caution' warning sign indicates that slight personal injury can occur if the appropriate safety precautions are not observed.

CAUTION!

'Caution' indicates that damage to property can occur if the appropriate safety precautions are not observed.

ATTENTION

'Attention' indicates that an unintended result or situation can occur if the corresponding information is not taken into account.



NOTE!

'Note' indicates important information relating to the product or highlights parts of the documentation for special attention.

QUALIFIED PERSONNEL

'Qualified personnel' are experts who are familiar with the installation, mounting, commissioning and operation of these types of products.



6 INTRODUCTION

The portable **M&C** oxygen analyser **PMA 10(S)** is a non-thermostated instrument which has been designed for continuous and discontinuous measurement of oxygen concentrations in dry and particle-free sample gas.

6.1 SERIAL NUMBER

The type plate with the serial number is located on the back of the analyser.

Please refer to this serial number if you have any questions about your PMA 10(S).or if you need to order spare parts or consumables.

7 APPLICATION

The **PMA 10(S)** is based on the magneto dynamic oxygen measuring cell of **M&C**.

This measuring principle is one of the most accurate methods for oxygen determination within the range of 0 to 100 vol% O₂. The robust measuring cell is unique in design and construction.

Due to the extremely fast response time of the M&C magneto-dynamic measuring cell with no stagnant volume as well as the negligible cross sensitivity from other sample gas components, the portable **M&C** oxygen analyser **PMA 10(S)** has a wide variety of applications. The analyser is a suitable and reliable instrument for monitoring oxygen concentrations in various gas analytical control applications including flue gas-, inert gas-, fermentation processes-, food packing machines-, ambient air- and laboratory process control measurements.

It is characterized by safety in operation, robustness, accuracy and the need of low maintenance.

8 TECHNICAL DATA

Oxygen analyser Series PMA®	Version PMA 10 and PMA 10S
Part No.	PMA 10 : 01 A 1000 = 230 V 50 Hz, 01 A 1000a = 115 V 60 Hz PMA 10S : 01 A 2000 = 230 V 50 Hz, 01 A 2000a = 115 V 60 Hz
Measuring ranges	selectable for 0-3, 0-10, 0-30 and 0-100 vol% O ₂ , linear PMA 10S additional 9x % - 100 % (e.g. 99 % - 100 %)
Indication	analogue / digital meter: analogue meter selectable for each range with a scale of 0-30 and 0-100 % digital meter, 3 1/2 digit 9 mm high LCD for 0-100 % O ₂ reading, selectivity 0.1 vol% O ₂
Output signal	0-1 V DC, non-isolated, load > 100 kΩ, for each selected range;
Response time for 90 % FSD	< 3 seconds at 60 NI/h air
Accuracy after calibration	analogue = ±1 % of span / digital = ±0.1 vol% O ₂ error of precision PMA 10S within additional measuring range : ±3 vol% O ₂ of measuring range
Reproducibility	analogue = < 1 % of span / digital = ±0.1 vol% O ₂ error
Influence of ambient temperature	zero point ±0.02 vol% O ₂ / °C; sensitivity ±0.1 vol% O ₂ / °C
Influence of barometric pressure	The oxygen reading varies in direct proportion to changes of the barometric pressure.
Influence of sample gas flow	variation in gas flow between 0-60 NI/h air will cause a difference of < 0.1 vol% O ₂ .
Sample gas inlet pressure	0.01 up to 1 bar g, (PMA 10 required admission pressure for competent flow rate, no pump inside)
Sample gas outlet pressure	Outlet of analyser must discharge freely into atmosphere.
Flow rate of sample gas	max. 60 NI/h air, adjustable with needle valve on the flowmeter 7-70 NI/h
Temperature of sample gas	-10 °C up to +40 °C (14 °F up to 104 °F), dry gas
Analyser temperature	according to ambient temperature, non heated version
Ambient temperature	-10 °C up to +55 °C (14 °F up to 131 °F)
Storage temperature	-20 °C up to +60 °C (-4 up to 140 °F), relative humidity 0-90 % RH
Power supply	internal power unit for 230 VAC standard or 115 VAC available (a)* ±10 %, 40-60 Hz, 8 VA
Electrical connections	mains supply: 3-pole chassis plug with 2 m of cable; signal: 3-pole plug
Materials in contact with sample gas	Platinum, Glass, Polypropylene, Stainless Steel 316, FPM, Epoxy resin
Sample gas connection	PP-hose nipple for DN 11-4 mm tube
Protection / electrical standard	IP 41 EN 60529 / EN 61010
Housing / colour	portable plastic housing / gray
Dimension / weight	height 150 mm (5.91"), width 202 mm (7.95"), depth 260 mm (10.24") / approx. 3 kg (6.61 lbs)
Options	
01 A 9000	Extra charge for signal output 4-20 mA incorporated in the analyser PMA 10/10S (0-20 mA on request), max. burden 300 Ω
01 A 9100	Extra charge for gas sample pump incorporated in analyser type PMA 10. Capacity: 0.9 NI/min without pressure.
01 A 9102	Extra charge for gas sample pump incorporated in analyser type PMA 10. Capacity: 1 NI/min without pressure.
01 A 9050	Extra charge for PMA 10 with battery operation, battery charger incorporated in the analyser
01 A 9150	Min.* oder Max.* Alarmkontakt, von 0-100 % O ₂ einstellbar Extra charge for alarm contact at analyser type PMA 10, adjustable from 0-100 % O ₂ . Potential-free changeover contact with plug at the rear of the housing. (not for PMA 10S)
01 A 9155	Extra charge for PMA 10 with Piezo acoustic alarm and automatic reset (30 s) (only in combination with alarm 01 A 9150). (not for PMA 10S)
01 A 9156	Extra charge for PMA 10 with Piezo acoustic alarm and manual reset (30 s) (only in combination with alarm 01 A 9150). (not for PMA 10S)
01 A 9160	Extra charge for qualification test according to TA-Luft + EN 14181 resp. 13. and 17. BImSchV of analyser type PMA 10. Incl. signal output: 4-20 mA (0-20 mA on request) (not for PMA 10S)

* Please specify with order.

In case the options alarm and pump are both required, a rechargeable battery is automatically obliged.

Option "TÜV approved" includes 0* / 4*-20 mA signal output, as further options only rechargeable battery and internal pump available.

9 DESCRIPTION

The **PMA 10** is a reliable and easy-to-operate instrument and immediately operable. The light-weight instrument is built into a portable housing. The four measuring ranges are displayed on the analogue meter with 30 % and 100 % scale and the 100 % O₂ range also on the digital meter. One output signal 0-1 V is available as standard. Sample gas connections as well as a connector for the output signal are located on the front panel of the analyser. The connectors for incoming power supply and optional O₂ alarm contact are located at the rear panel. The sample gas enters the analyser via an internal protective fine-filter. The required flow rate can be adjusted at the flowmeter with a needle valve, mounted on the front panel upstream the M&C measuring cell. Options: mA-output signal, O₂ alarm, rechargeable battery, internal pump and TÜV certificate.

The **PMA 10S** oxygen purity analyser, being an extended version of the PMA 10, is provided with an electronic suppression system which enables oxygen purity measurements within the expanded 99-100 vol% range. This measuring range is displayed on the analogue meter whilst the digital indicator remains for the 0-100 % reading. The electronic zero suppression system may be selected by means of a push button switch which is located on the control panel of the instrument.

The **PMA 10S** analyser can normally be used also for its standard PMA10 functions. Oxygen purity measurements could only be made discontinuously. The measuring accuracy of the analyser can be maintained when calibration of the instrument with a certified gas takes place before the measurement procedure in order to avoid influence of ambient temperature and pressure. A measurement of 1 vol% can be easily realized whilst the maximum value remains at 100 vol%. Other measurement within this range can be performed.

The physical measuring principle is based on the magneto-dynamic oxygen measuring cell and is one of the most accurate methods for oxygen determination within the range of 0 - 100 vol% O₂. The measuring cell has a low volume of only 2 ml, is very robust, has an extremely low drift and a very fast response time. The 90 %-time is approximately 3 sec. and is achieved by a gas flow rate of 60 NI/h through the measuring cell. The change of the flow in the range of 0 – 60 NI/h air causes a change of the O₂ indication of < 0.1 vol% O₂.

An internal power supply unit provides the analyser with the necessary supply voltage. At the rear side there is the low heat device socket.



NOTE!

The analyser is not thermostated and should be operated only in areas with constant ambient temperature. If this is not possible, the analyser has to be calibrated before every measurement, to guarantee the accuracy of measurement.

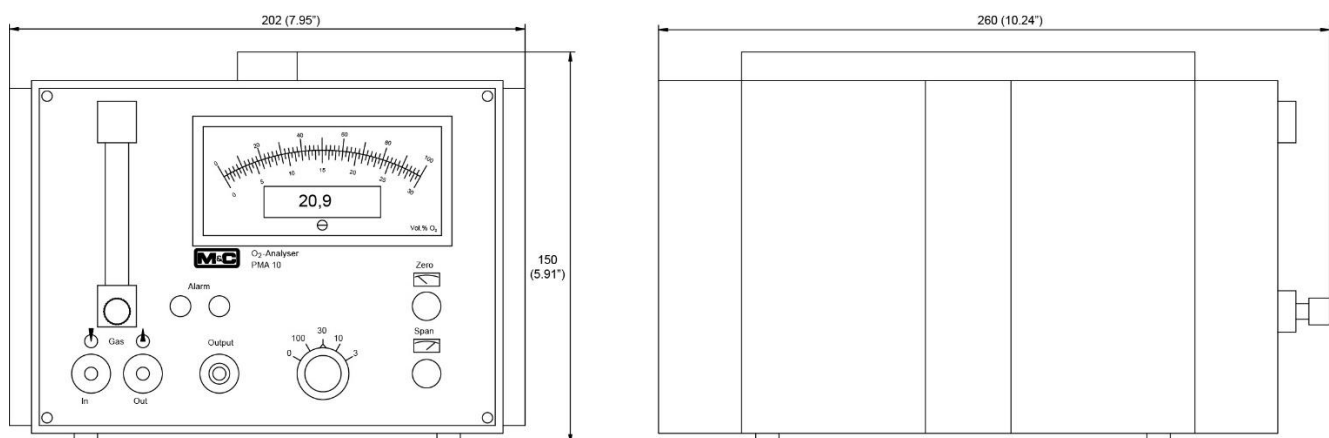

Figure 1 Dimensions

9.1 FRONT PANEL

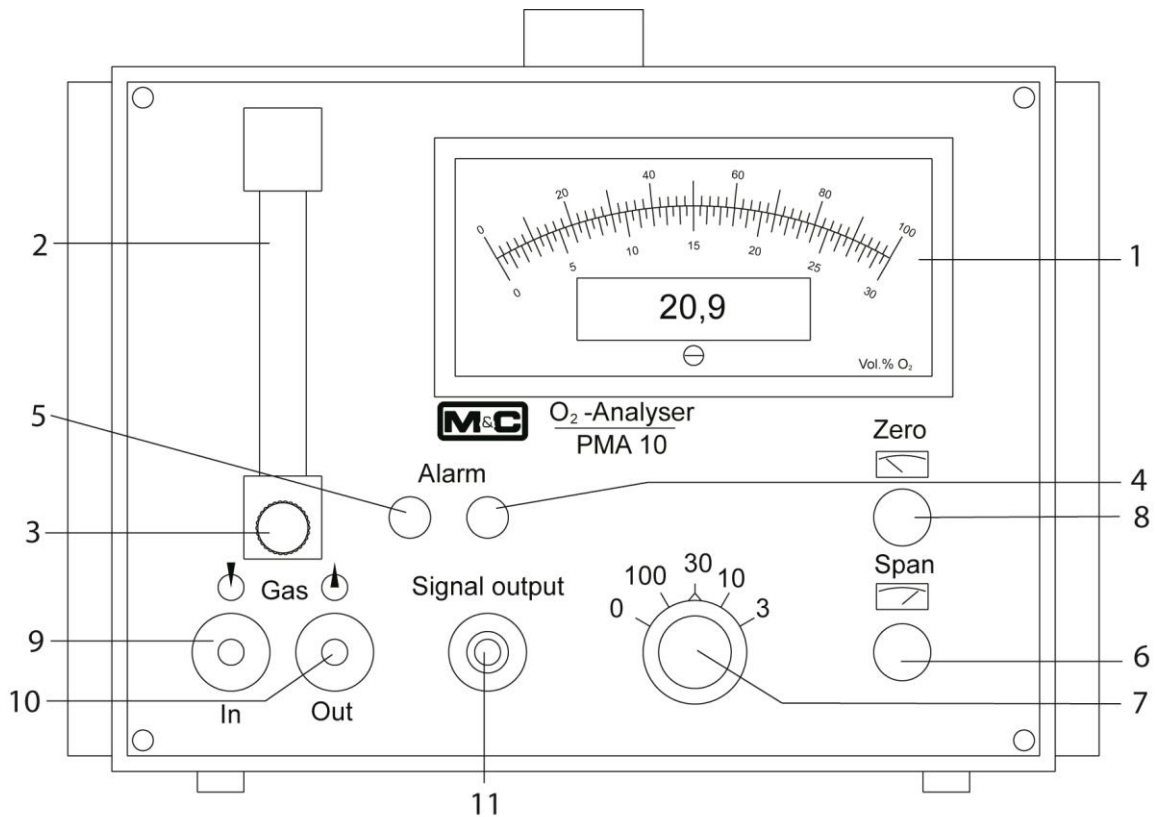

Figure 2 Front panel

- 1 Analog-/ digital-indication
- 2 Flow meter
- 3 Needle valve 7 – 70 NI/h
- 4 Alarm potentiometer – option (PMA 10) or LED active measuring range (PMA 10S)
- 5 Alarm-button – option (PMA 10) or switch for suppressed measuring range (PMA 10S)
- 6 Span potentiometer
- 7 Measuring range selector switch
- 8 Zero potentiometer
- 9 Sample gas - In DN 11-4 mm
- 10 Sample gas - Out DN 11-4 mm
- 11 Signal - Out 3-pole

At the rear side there are:

- Low heat device socket with 2 fine fuses for power supply
- Push button for battery check - Option
- Switch for the sample gas pump - Option
- 3 pole bushing for alarm contact outlet - Option

9.2 GAS FLOW DIAGRAM OF THE ANALYSER PMA 10(S)

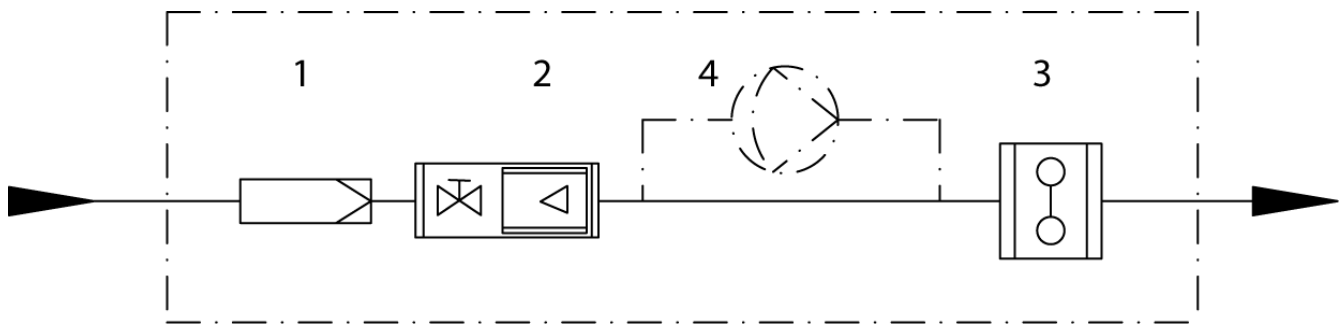

- | | | | |
|---|------------------------------|---|--------------------------|
| 1 | Fine filter | 3 | Measuring cell |
| 2 | Flow meter with needle valve | 4 | Sample gas pump - Option |

Figure 3 Gas flow diagram PMA 10(S)

9.3 OPTIONS

9.3.1 APPROVAL ACCORDING TO 13. AND 17. BIMSCHV AND TA-LUFT (NOT FOR PMA 10S)

The approval happened by: Rheinisch-Westfälischer Technischer Überwachungs-Verein e.V. Essen. These devices have the label "TÜV eignungsgeprüft" at the front side. In connection with this approval a 4 -20 mA output is always necessary.

9.3.2 OUTPUT SIGNAL

For output signal 0 – 1 V an output signal 0 – 20 or 4 – 20 mA is available as option. The 3-pole connection bushing is provided on the front panel of the analyser.

9.3.3 RECHARGEABLE BATTERY

The analyser **PMA 10(S)** can be finished with a rechargeable battery. Hereby an operation off the line is possible. The internal mains adapter than simultaneously is used as battery charger.

9.3.4 SAMPLE GAS PUMP

A sample gas pump with a capacity of approx. 1 l/min – without pressure can be integrated in the device. The pump is designed for short time rating only. For long-term operation an external sample gas pump has to be used.

9.3.5 ALARM CONTACT OUTLET (NOT FOR PMA 10S)

It is possible to adjust the alarm value via a potentiometer on the front panel to any value and it is switched as a min. or max. contact. The outlet is a potential-free change over contact that is lead through via a plug at the rear side.

Additionally an acoustic alarm with automatic or manual reset (30 sec.) is integrable.

10 THE MEASURING PRINCIPLE

Oxygen is a gas with a significant paramagnetic susceptibility. The molecules of oxygen are attracted much more strongly by a magnetic field than the molecules of other gases.

The measuring principle shown in the following is benefitting from these characteristics of the oxygen. The great advantage of the paramagnetic measuring principle is the highly reduced cross sensitivity of the measurement to other components in the sample gas.

Figure 2 shows the diagram of the measuring cell as well as the optical system for the detection of the dumbbell's movement.

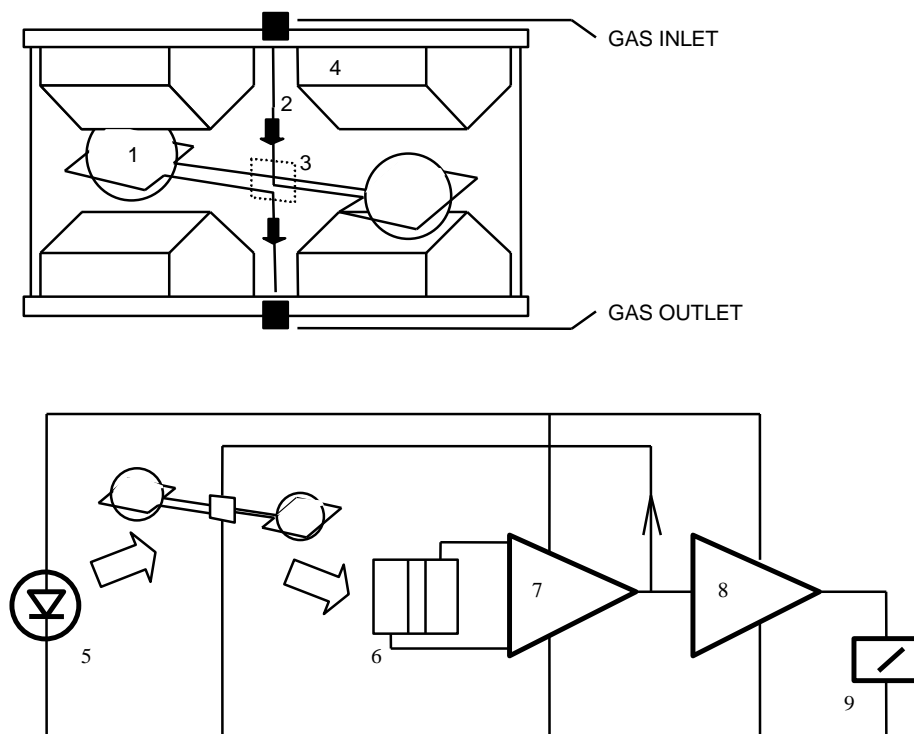

Figure 4 Scheme of the measuring cell and optical signal processing

The measuring cell consists of two nitrogen-filled spheres ① which are arranged in the form of a dumbbell. In the dumbbell's central point of rotation, a small mirror ③ is placed. The dumbbell is surrounded by a wire coil needed for the compensation procedure. The described system is fixed rotationally symmetrical inside a glass tube via a tightening strap out of platinum ② and is screwed up with two pole pieces ④.

Two permanent magnets are producing an inhomogeneous magnetic field. When oxygen is flowing in, the molecules of the oxygen are drawn into the magnetic field. In consequence, the lines of electric flux on the cuneiform pole pieces ④ are compressed. The nitrogen-filled diamagnetic spheres are pushed out of the magnetic field. This causes a rotation of the dumbbell. The rotation is detected via an optical system consisting of mirror ③, projection LED ⑤ and photoelectric cell ⑥.

In case the dumbbell is pushed out of the magnetic field, the tension of the photoelectric cell is immediately changed. The measuring amplifiers ⑦ and ⑧ are producing a respective current which develops via the wire coil on the dumbbell an electro-magnetic load moment. The load moment is resetting the dumbbell into its zero position.

Every change of the oxygen concentration produces a lineary proportional change of the compensation current and can be read directly in % O₂ as oxygen value on the display ⑨.

Due to its very small stagnant volume (2 cm³) and the direct flow of the **M&C** measuring cell, an extremely fast response time (T₉₀-time) of 1 second for a high gas flow can be realized.

11 RECEIPT OF GOODS AND STORAGE

The analyser **PMA 10(S)** is a completely pre-installed unit.

- Please take the analyser and possible special accessories carefully out of the packaging material immediately after arrival, and compare the goods with the items listed on the packing list;
- Check the goods for any damage caused during delivery and, if necessary, notify your transport insurance company without delay of any damage discovered.



NOTE!

The oxygen analyser PMA 10(S) must be stored in a wheather - protected and frost-proof area !

12 INSTALLATION

The **PMA 10(S)** is intended for mobile operation at always changing locations. In combination with a good gas conditioning (e.g. PSS-5, Part No. 01 G 1100) a long lasting operability and a minimum of maintenance is guaranteed.



CAUTION!

The sample gas has to be dust free and dry to prevent a contamination and condensation in the analyser.

Basically always connect a fine filter with a filter grade of at least 2 µm (e.g. type FP-2T, Part No. 01 F 1200) upstream.



CAUTION!

In case of outdoor operation protect the analyser against sun, wind and rain.

At the installation location constant climatic ambient conditions (pressure, temperature) are necessary to prevent a distortion of the measurement and a condensation in the measuring cell in case the ambient temperature is falling below the dew point temperature of the sample gas.

A vibration-free location is ideal for mounting; if this is not possible, appropriate measures have to be taken. The analyser must not be installed in direct proximity of heat sources.

The position of operation is not necessarily horizontal.



DANGER!

The analyser is allowed to be operated only in non-hazardous areas and with non-ignitable gases and gas mixtures.

12.1 CONNECTION OF SAMPLE GAS INLET AND SAMPLE GAS OUTLET

The sample gas inlet and outlet are placed on the front panel of the analyser and have a hose nipple connection DN 11 – 4 mm.

- Connect the sample gas inlet with a corresponding gas conditioning with e.g. a flexible PVC hose DN4/6.

ATTENTION

**Avoid back pressure in the sample gas outlet because an increase of pressure will distort the oxygen indication.
Do not bend the connection hoses.**

13 STANDARD GAS CONDITIONING SYSTEM

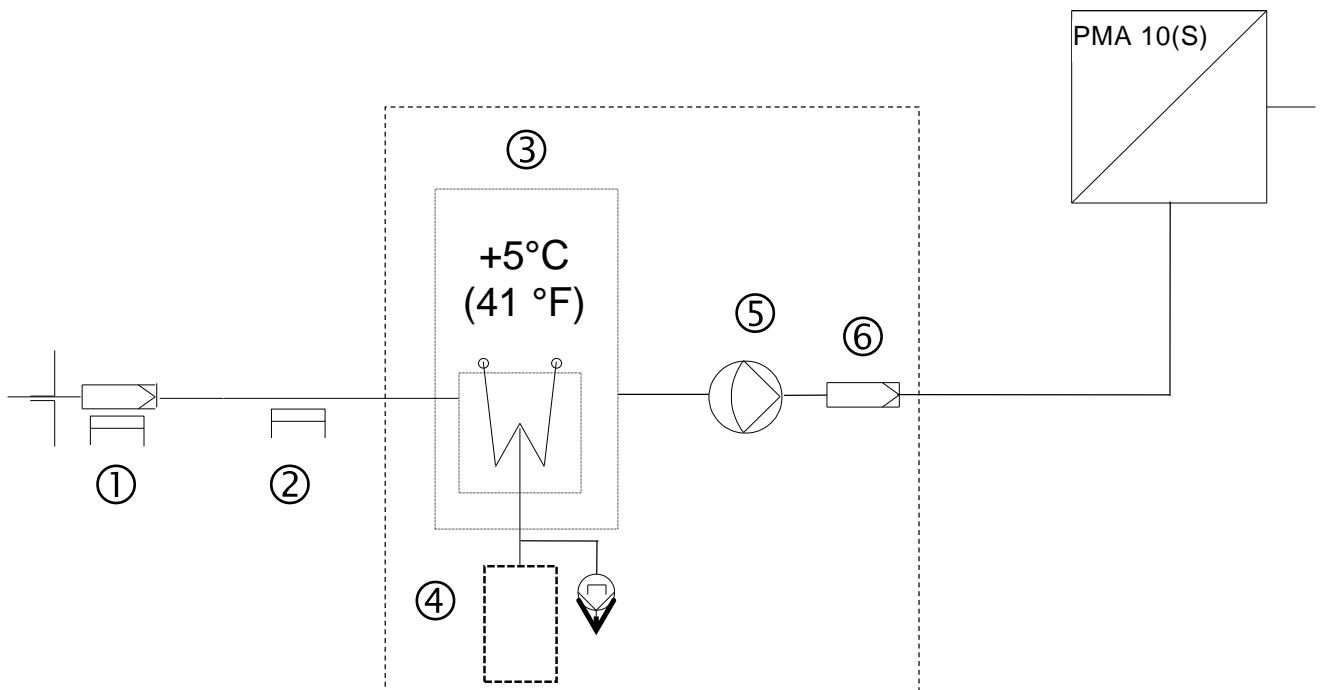

Figure 5 Standard gas conditioning system

- 1 : Heated gas sample probe (e.g. portable probe PSP4000-H)
- 2 : Heated gas sample line (e.g. PSP4M4/6)
- 3 : Sample gas cooler
- 4 : Peristaltic pump or condensate collecting vessel
- 5 : Diaphragm pump
- 6 : Fine filter (3 - 6 e.g. portable gas sampling system PSS-5)

14 ELECTRICAL CONNECTION



CAUTION!

False supply voltage can damage the equipment. When connecting the equipment, please ensure that the supply voltage is identical with the information provided on the model type plate!

At the rear side there is the low heat device socket. A 2 m (6.56 ft) connection cable with low heat device connector and earthing type plug is included in the scope of delivery.

14.1 SIGNAL OUTPUT

The **PMA 10(S)** has a signal output of 0 – 1 V as standard, that is available in the chosen measuring range at the 3-pole bushing in the front of the analyser (Pin 1/- und 3/+).

With option mA-output, additionally a signal of 0 - 20 mA or 4 - 20 mA is available at the 3-pole bushing in the front of the analyser (Pin 1/- und 2/+).

The output signals are not galvanically isolated.

For the connection of the signal output an adequate plug is provided.

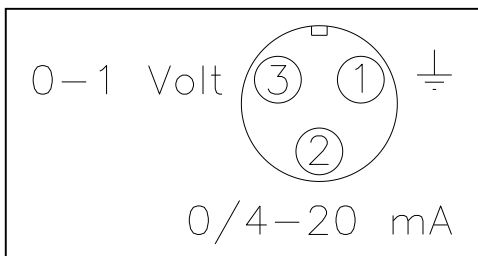

Figure 6 Plug connection signal output

14.2 OPTION ALARM CONTACT OUTPUT

The alarm contact output is designed as MIN- as well as MAX-contact. The factory default setting is a MAX-contact.

If a MIN-contact is favoured, the 4 screws of the front panel have to be removed and the switch S2 on the alarm-board has to be switched. For output a relais contact (change over contact) and optionally a buzzer is available. The intermitting buzzer switches off after 30 seconds automatically or has a manual reset as option. The relais contact is lead to a female plug at the rear side. A corresponding plug with the following assignment is included in the scope of delivery (see also Fig. 7) :

Contact	Assign-ment	Explanation	Contact rating
1	mc	Tie point	max. 2 A max. 24 VDC /100 VAC
2	nc	Normally closed	
3	no	Normally open	

14.2.1 ADJUSTMENT OF THE ALARM THRESHOLD

For adjustment of the alarm threshold on the front panel there is a potentiometer marked with "alarm" and aside a push-button:

- Actuate the push-button and keep it pressed. Now the digital indication of the indication instrument shows the alarm threshold.
- Adjust the alarm threshold in the range of 0 – 100 vol% O₂ at the alarm potentiometer with suitable screw driver.
- After adjustment of the desired alarm threshold release push button. The alarm threshold now is adjusted and the digital indication again shows the current measurement.

The position of the measuring range selector switch is not relevant for the adjustment of the alarm threshold.

15 CONNECTIONS ON THE REAR SIDE



Figure 7 Rear side

- ① Low heat device socket with 2 fine fuses for power supply
- ② Space for push-button for battery check - Option
- ③ Space for pump switch ON-OFF - Option
- ④ Space for 3-pole bushing for alarm contact output - Option

16 STARTING UP



CAUTION!

False supply voltage can damage the equipment. When connecting the equipment, please ensure that the supply voltage is identical with the information provided on the model type plate!

- Check electrical connections and gas connections.
- Switch on mains voltage.
- Turn measuring range selection switch from '0' to the desired measuring range. The analyser is ready for operation immediately.

CAUTION!

If during transport the analyser was exposed to extreme changes of temperature, an adequate time for temperature adaption has to be observed, to prevent condensation in the device.

16.1 EXECUTION WITH RECHARGEABLE BATTERY

Check charge condition of the battery. To check the battery, the device needs to be turned on. Press the button 'battery check' at the rear side of the device. The digital indication has to show a value of min. 83. If the shown value is lower than 83, the battery needs to be recharged. For this connect the low heat device connector of the provided connection cable at the rear side with the low heat device socket and the earthing type plug with the mains power. In position '0' of the measuring range selector switch the battery is charged in approximately 14 hours.



NOTE!

Never fully discharge the battery (battery check indication < 83), hereby the life time is reduced.

The analyser with battery also can be operated always at the mains.

17 CALIBRATION

The accuracy of an analyser mainly is dependent on its calibration.



NOTE!

Before calibration it has to be assured that the calibration conditions correspond to the conditions during measurement. The flow rate, the ambient temperature and the barometric pressure conditions have to be constant. Under this terms a calibration of the analyser is necessary approximately one time a week to maintain the accuracy. If flow rate, ambient temperature or barometric pressure conditions are changing significantly, a new calibration is necessary.

During calibration the device must not be exposed to vibrations.

For zero calibration of the analyser an oxygen-free gas, mostly nitrogen (N₂ 5.0) is used.

For span calibration with **M&C** O₂-analysers it is not necessary to use special test gas mixtures, because of the measuring principle and the linear measuring ranges. Dry and clean air is sufficient.

For measurement concentrations > 40 % O₂ a calibration with corresponding test gas could be possibly recommendable.

17.1 ZERO CALIBRATION

- Connect a flexible PVC- or FEP-hose with the pressure reducer of the N₂-zero-gas bottle. The pressure reducer should have an output control range of max. 0 – 1.5 bar abs.

CAUTION! The outlet pressure is only allowed to be adjusted at max. 0.1 bar. Otherwise the measuring cell of the analyser will be destroyed.

- Open the bottle valve and then the closed pressure reducer outlet valve and purge the pressure reducer and the complete hose line for approximately 5 s. the pressure reducer and the complete hose line.
- Check the adjusted control pressure and reduce if necessary to ≤ 0.1 bar, then shut off the pressure reducer valve again.
- Connect the hose end of the zero-gas bottle connection to the gas inlet of the analyser.
- Open the pressure reducer valve slowly, to avoid pressure peaks.
- Adjust the flow rate to 50 NI/h at the flow meter.



NOTE!

Always calibrate at the flow rate that is adjusted for the measurement too.

- Wait approximately 20 – 30 s until the indication has stabilised.
- If necessary adjust zero accurately to 0 % O₂ with a screw driver at the zero potentiometer in the front panel.
- Check output signals at 0.0% O₂ :

Output signal	Measurement
0-1 V	0 V
0-20 mA	0 mA
4-20 mA	4 mA



NOTE!

If a gas mixture is analysed, the single gas components have to be checked concerning potential cross sensitivity and regarded for zero calibration. (see chapter 17.1.1 and 17.1.2).

- Shut off pressure outlet valve and bottle valve.
- Disconnect hose connection from the analyser. Schlauchverbindung am Analysator entfernen.

Zero calibration is finished.



NOTE!

After zero calibration the span has to be calibrated too.

17.1.1 CROSS SENSITIVITIES

The following table shows the cross sensitivities of the most important gases at 20 °C and 50 °C. All values are based on a zero calibration with N₂ and a span calibration with 100 vol% O₂. The deviations are each valid for 100 vol% of the respective gas.

Gas	Molecular formula	20 °C (68 °F)	50 °C (122 °F)
Acetaldehyde	C ₂ H ₄ O	- 0.31	- 0.34
Acetone	C ₃ H ₆ O	- 0.63	- 0.69
Acetylene	C ₂ H ₂	- 0.26	- 0.28
Ammonia	NH ₃	- 0.17	- 0.19
Argon	Ar	- 0.23	- 0.25
Benzene	C ₆ H ₆	- 1.24	- 1.34
Bromine	Br ₂	- 1.78	- 1.97
Butadiene	C ₄ H ₆	- 0.85	- 0.93
n-Butane	C ₄ H ₁₀	- 1.10	- 1.22
Iso Butylen	C ₄ H ₇	- 0.94	- 1.06
Chlorine	Cl ₂	- 0.83	- 0.91
Diacetylene	(CHCl) ₂	- 1.09	- 1.20
Nitrous monoxide	N ₂ O	- 0.20	- 0.22
Ethane	C ₂ H ₄	- 0.43	- 0.47
Ethylbenzene	C ₈ H ₁₀	- 1.89	- 2.08
Ethylene	C ₂ H ₄	- 0.20	- 0.22
Ethylene glycol	(CH ₂ OH) ₂	- 0.78	- 0.88
Ethylene oxide	C ₂ H ₄ O ₂	- 0.54	- 0.60
Furan	C ₄ H ₄ O	- 0.90	- 0.99
Helium	He	+ 0.29	+ 0.32
n-Hexane	C ₆ H ₁₄	- 1.78	- 1.97
Hydrogen chloride	HCL	- 0.31	- 0.34
Hydrogen fluoride	HF	+ 0.12	+ 0.14
Hydrogen sulfide	H ₂ S	- 0.41	- 0.43
Carbon dioxide	CO ₂	- 0.27	- 0.29
Carbon monoxide	CO	- 0.06	- 0.07
Krypton	Kr	- 0.49	- 0.54
Methane	CH ₄	- 0.16	- 0.17
Methanol	CH ₄ O	- 0.27	- 0.31
Methylen chloride	CH ₂ Cl ₂	- 1.00	- 1.10
Methyl propene	C ₄ H ₈	- 0.94	- 1.06
Monosilan	SiH ₄	- 0.24	- 0.27
Neon	Ne	+ 0.16	+ 0.17
n-Octane	C ₈ H ₁₈	- 2.45	- 2.70
Phenol	C ₆ H ₆ O	- 1.40	- 1.54
Propane	C ₃ H ₈	- 0.77	- 0.85
Propylene	C ₃ H ₆	- 0.57	- 0.62
Propylene chloride	C ₃ H ₇ Cl	- 1.42	- 1.44
Propylene oxide	C ₃ H ₆ O	- 0.90	- 1.00
Oxygen	O₂	+100.00	+100.00
Sulfur dioxide	SO ₂	- 0.18	- 0.20
Sulfur fluoride	SF ₆	- 0.98	- 1.05
Monosilane	SiH ₄	- 0.24	- 0.27
Nitrogen	N₂	0.00	0.00
Nitrogen dioxide	NO ₂	+ 5.00	+ 16.00
Nitrogen monoxide	NO	+ 42.70	+ 43.00
Styrene	C ₈ H ₈	- 1.63	- 1.80
Toluene	C ₇ H ₈	- 1.57	- 1.73
Vinyl chloride	C ₂ H ₃ Cl	- 0.68	- 0.74
Vinyl fluoride	CH ₃ F	- 0.49	- 0.54
Water (Steam)	H ₂ O	- 0.03	- 0.03
Hydrogen	H ₂	+ 0.23	+ 0.26
Xenon	Xe	- 0.95	- 1.02

17.1.2 CONSIDERATION OF CROSS SENSITIVITIES

The selectivity of the above mentioned measuring principle is based on the high susceptibility of oxygen to other gases (see table).

The following examples shall show how cross sensitivities can be considered for the zero calibration.

Example 1: Determination of the rest content of oxygen in a 100 % carbon dioxide (CO₂) protective atmosphere at 20 °C (68 °F)

In the table of cross sensitivities you can read the value for CO₂ at 20 °C (68 °F) of -0.27. This means that for calibration with nitrogen the zero point must be set to +0.27 % in order to compensate the deviation of the display.

In this example, the atmosphere contains exclusively CO₂ and O₂. For this reason, the influence of cross sensitivity can be eliminated without problem by using carbon dioxide (CO₂) instead of nitrogen for the zero calibration.

Example 2: Determination of the oxygen content of a gas mixture at 20 °C (68 °F)

1 vol-% C₂H₆ (Ethane);
 5 vol-% O₂;
 40 vol-% CO₂;
 54 vol-% N₂.

Zero point calibration with nitrogen (N₂).

The cross sensitivity values of above table are based on 100 vol% of the respective gases. Therefore, a conversion must be made to the effective volume concentration. In principle, the following is valid:

$$\text{Effective cross sensitivity} = \frac{\text{Table value} \times \text{Volume concentration}}{100} \quad [\text{vol}\%]$$

For the components of the gas mixture, the following values are found:

C₂H₆: -0.0043 vol%;

CO₂: -0.1080 vol%;

N₂ : 0.0000 vol%.

$\Sigma = -0.1123 \text{ vol}\%$

To determine the sum of cross sensitivity as exactly as possible, a correction factor has to be determined, because the sum of cross sensitivities relates not on 100 % but on 100 % minus the oxygen concentration (here 95 %).

The correction factor is calculated as follows:

$$\text{Correction factor} = \frac{100}{(100 - \text{O}_2\text{-concentration})}$$

It is incidental:

$$\frac{100}{(100 - 5)} = 1.0526$$

For the gas mixture the rectified sum cross sensitivity then is calculated in good approximation:

$$1.0526 \times -0.1123 \text{ vol\%} = \underline{\underline{-0.1182 \text{ vol\%}}}$$

The rectified sum cross sensitivity with change of sign now can be used for the correction of the zero calibration. In this case zero had to be adjusted at +0.1182 vol%.

In case the cross sensitivities should be ignored in the above mentioned example, this would result in a relative error of approximately 2 %.



NOTE!

After zero calibration the span has to be calibrated too.

17.2 SPAN CALIBRATION

Before span calibration a finished zero calibration is necessary.

Connect a flexible PVC- or FEP-hose with the pressure reducer of the N₂-zero-gas bottle. The pressure reducer should have an output control range of max. 0 – 1.5 bar abs..

CAUTION! The outlet pressure is only allowed to be adjusted at max. 0.1 bar. Otherwise the measuring cell of the analyser will be destroyed.

- Open the bottle valve and then the closed pressure reducer outlet valve and purge the pressure reducer and the complete hose line for approximately 5 sec. the pressure reducer and the complete hose line.
- Check the adjusted control pressure and reduce if necessary to ≤ 0.1 bar, then shut off the pressure reducer valve again.
- Connect the hose end of the instrument air or check gas bottle connection to the gas inlet of the analyser.
- Open the pressure reducer valve slowly, to avoid pressure peaks.
- Adjust the flow rate to 50 NI/hr at the flow meter.

**NOTE!**

Always calibrate at the flow rate that is adjusted for the measurement too.

- Wait approximately 20 – 30 sec. until the indication has stabilised.
- If necessary adjust span accurately according to the check gas concentration with a screw driver at the span potentiometer in the front panel. In case of air e.g. to 20.9 % O₂.
- Check output signals at 20.9 % O₂ :

Output signal	Measurement range 100 % O ₂	Measurement range 30 % O ₂
0-1 V	0.209 V	0.697 V
0-20 mA	4.18 mA	13.93 mA
4-20 mA	7.34 mA	15.15 mA

- Shut off pressure reducer valve and bottle- resp. Instrument air valve resp. integrated sample gas pump.
- Disconnect hose connection at the analyser.

Determination of the output signal:

$$\frac{(S_e - S_{np}) \text{ V resp. mA} \times \text{gas concentration vol\% O}_2}{\text{upper range value vol\% O}_2} + S_{np}$$

S_e = Final value, signal output

S_{np} = Zero, signal output

- Shut off pressure reducer output valve and bottle valve. Disconnect hose connection at the analyser.

The span calibration is finished.

**NOTE!**

If during the span calibration great variations have to be compensated (>2 % O₂) at the potentiometers, a second zero and span calibration is reasonable.

18 MEASURING

For the first starting up at a new location, all steps in chapter 16 and 17 have to be performed. By the requirements of precision the interval of the new calibration can be carried out daily or weekly.

CAUTION! The sample gas must be free from all liquid or solid particles, i.e. the dew point of the gas must be below the equipment temperature so that no condensate will occur inside the equipment. If necessary, lower the dew point by means of a cooler or dryer. For dust filtration use a filter of 2 micron porosity !

We will be pleased to inform you about an optimal gas conditioning

The analyser now is ready for operation.

19 CLOSING DOWN

In case of a short time closing down of the the analyser no further precautions are required.

In case of a closing down of the analyser for a longer period, it is recommended to flush the analyser with dry and clean inert gas (eg. surrounding air) in order to prevent a damage of the measuring cell by aggressive and corrosive liquid gases.

For analyser with option rechargeable battery it is recommended for short or long term closing down to remain the analyser at the mains. Hereby a deep discharge of the rechargeable battery will be avoided and the device always is 100 % ready for operation .

20 MAINTENANCE

The analyser, woking with a physical measuring principle, requires no intensive and complex maintenance. But the preceding components necessary for the sample gas conditioning are to be maintained with special attention according to the respective operating manuals.

The calibration of zero and span is to be effected with the corresponding test gases according to stability of the operating conditions and to the demands on the accuracy. Recommended interval of calibration for standard applications: 1 x per week.

20.1 CHECK AND CHANGE OF THE INTERNAL FILTER ELEMENT

The internal fine filter should be checked regularly for contamination and changed if necessary. For a change the device has to be opened as follows:

- Take analyser off the mains.
- Loosen front quick-opening screw 1 of the handle.
- Loosen corrugated-head screw of the right hinge pin, extract the pin and open the device.
- Pull hose 7 off the filter inlet and unscrew filter body (4, 5, 6).
- Unscrew filter element clamp 4 and change filter element 5.
- Reassamble again in reverse order.

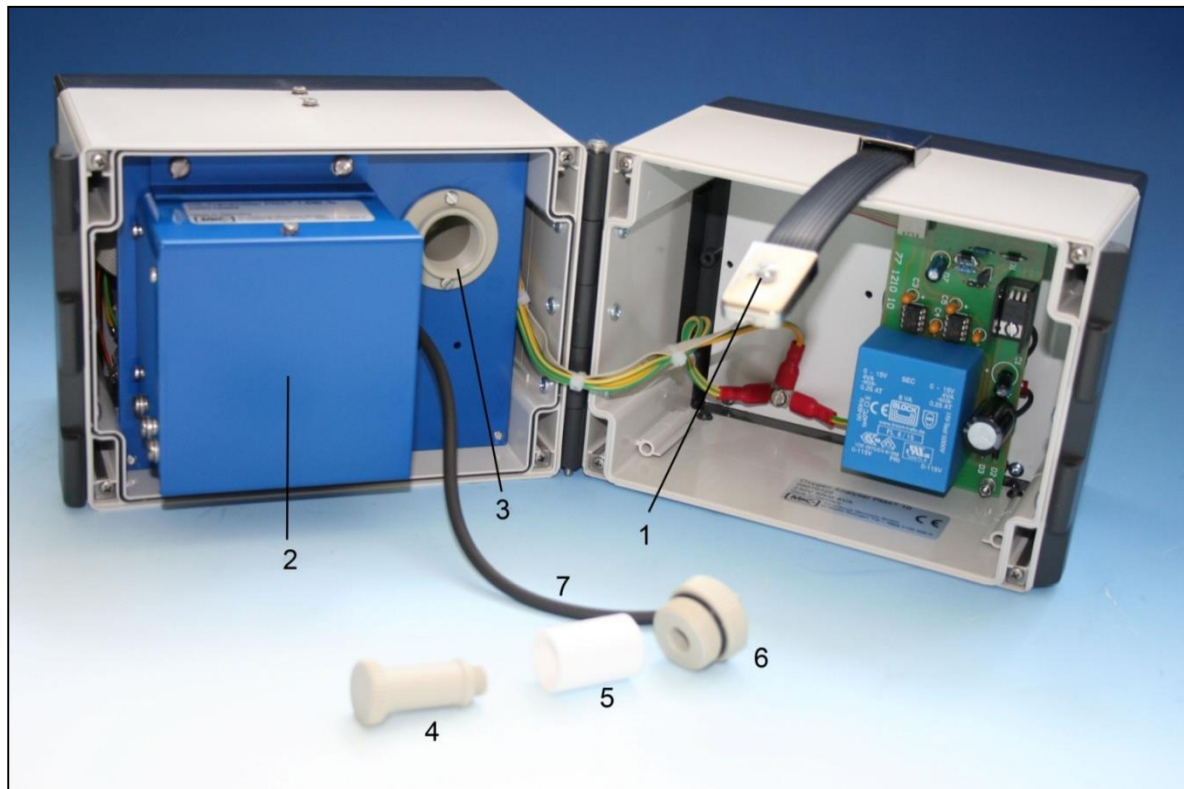

- | | |
|------------------------------------|------------------------------------|
| 1 Quick-opening screw | 5 Filter element |
| 2 O ₂ -transmitter-unit | 6 Filter head with filter inlet |
| 3 Filter body | 7 Connection hose gas IN to filter |
| 4 Filter element clamp | |

Figure 8 PMA 10(S) with open housing

21 TROUBLE SHOOTING

Error	Possible reason	Check/Repair
No indication	No supply voltage	Check supply voltage according to type plate. Check whether mains cable is plugged in accurately. Check fine fuse in the low heat device socket.
No sample gas flow	Sample line or filter is blocked Contamination of the internal diaphragm pump	Check sample system. Loosen hose at the pump head and check whether gas flow is present. Possibly open pump head and clean valves, diaphragm and pump head with a soap solution.

22 SPARE PARTS LIST

Wear, tear and replacement part requirements depend on specific operating conditions. The recommended quantities are based on experience and they are not binding.

Oxygen analyser PMA 10(S)					
(C) Consumable parts (R) Recommended spare parts (S) Spare parts					
					Recommended quantity being in operation [years]
Part No.	Indication	C/R/S	1	2	3
90 A 0100	Filter element 0.1 µm glass fibre PMA 10(S)	C	4	8	12
90 A 0068	O-Ring internal filter PMA 10(S)	R	2	4	6
90 A 0020	Zero potentiometer 5 k	S	-	-	1
90 A0025	Span potentiometer 1 k	S	-	-	1
90 A 0010	Measuring cell PMC 1	S	-	-	1
90 A 0015	Flowmeter glass 7-70 NI/h	R	-	-	1
90 A 0085	Signal output plug for PMA 10(S)	S	-	-	1
90 A 0070	Nipple PP for sample gas output PMA 10(S)	R	-	-	1
90 A 0075	Nipple PP for sample gas input PMA10(S).	R	-	-	1
90 A 0045	Spare pump 0.9 l/min PMA 10(S)	S	-	1	1

23 APPENDIX

- Component buildup



Further product documentation can be seen and downloaded from our home page:
www.mc-techgroup.com

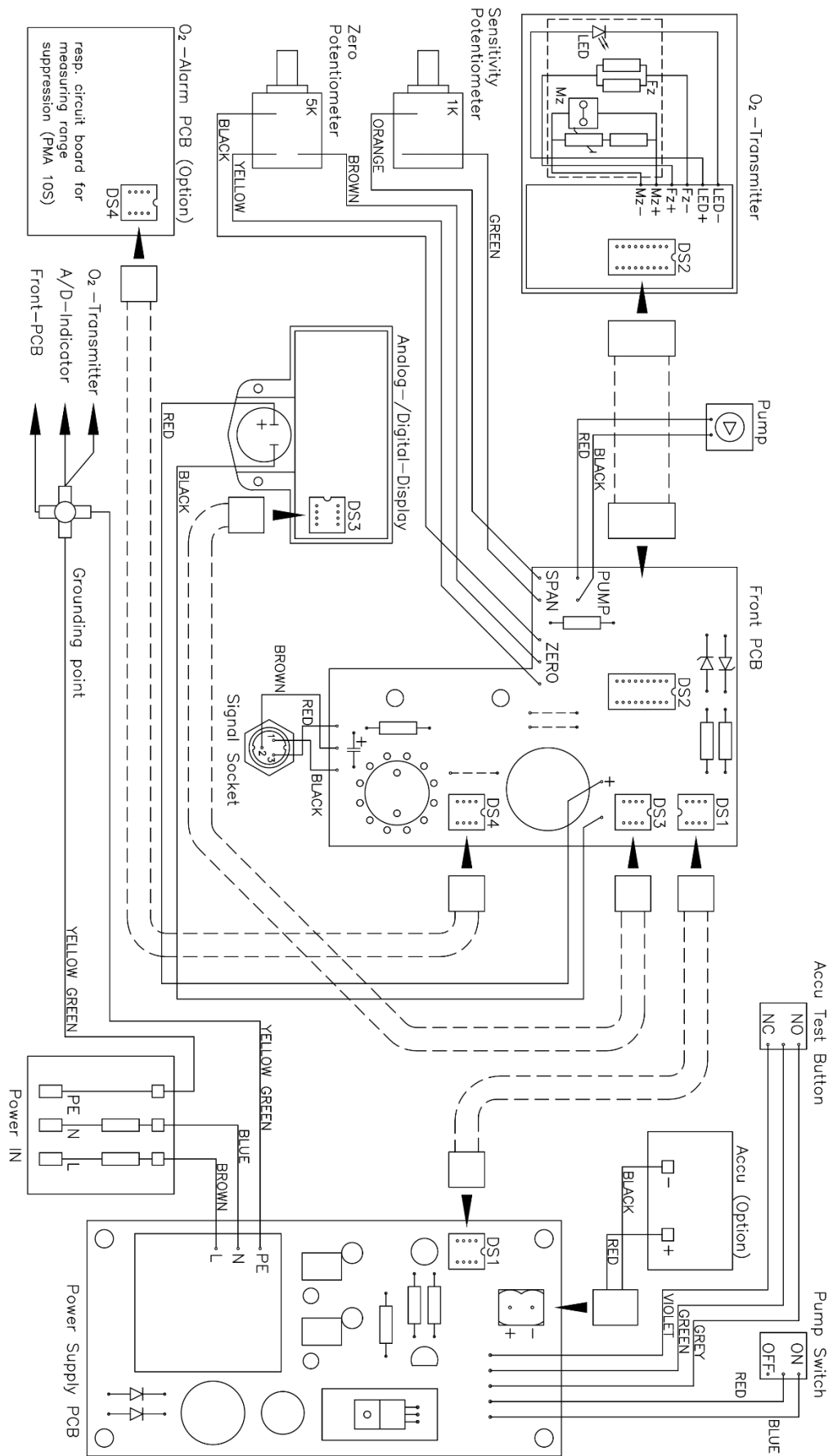

Figure 9 Component buildup (Drawing-No.: 2355-5.01.0)