



SR25.2

Peristaltic Pump Series SR25®

SR25.2, SR25.2-G, SR25.2-W

SR25.3, SR25.3-G, SR25.3-W

SR25.6, SR25.6-G, SR25.6-W

Special Features

- **Reliable condensate removal**
- **With return stop**
- **Self-priming**
- **Slow speed**
- **Tubing with long service life**

Application

The peristaltic pump series SR25 has been specially developed for condensate removal in analysis applications. It ensures a continuous condensate discharge in gas coolers, condensate collecting vessels, etc. A synchronous motor and the gearing unit with return stop prevent the condensate from flowing back.

The capacity of 0.3 l/h guarantees a safe condensate removal, for example when cooling 850 l/h sample gas with an initial dew point of +70 °C [158 °F].

- The peristaltic pump SR25.2/3/6-W can be used as a panel mounting and built-in unit.
- Different models can be used depending on the required pumping capacity of the peristaltic pump. The SR25.3 can be used for up to 1 rpm, the SR25.2 for 5 rpm, and the SR25.6 for 10 rpm.

Description

The peristaltic pump series SR25 is self-priming and designed for continuous operation. It consists of 3 compact parts:

- synchronous motor
- gearing unit with return stop and
- pump head.

The slow speed, the two PVDF contact pulleys and the different tubing materials guarantee a good mechanical and chemical resistance with a long service life. Pre-assembled flexible tubing sets make it easy to replace tubes, even without using any tools. The tube connector DN 4/6 also allows connecting a PTFE tube.

- The peristaltic pump SR25 is equipped with 230 V/50 Hz or 115 V/60 Hz power supply.
- The peristaltic pump SR25.2/3/6 is designed as a built-in unit for coolers. Up to four peristaltic pumps SR25.2/3/6 can be installed e.g. in the EC electric gas cooler (see data sheet "Gas Cooler Series EC®, Version ECS and EC-EX for 4 x 250 NI/h").
- The peristaltic pump SR25.2/3/6-G is supplied in a wall-mounted housing.

Dimensions

Peristaltic pump SR25.2

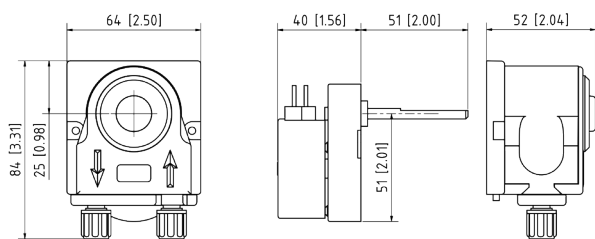

Peristaltic pump SR25.2-W

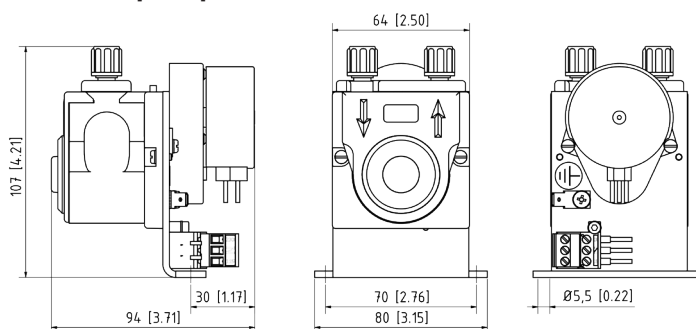

Peristaltic pump SR25.2-G in wall-mounting housing

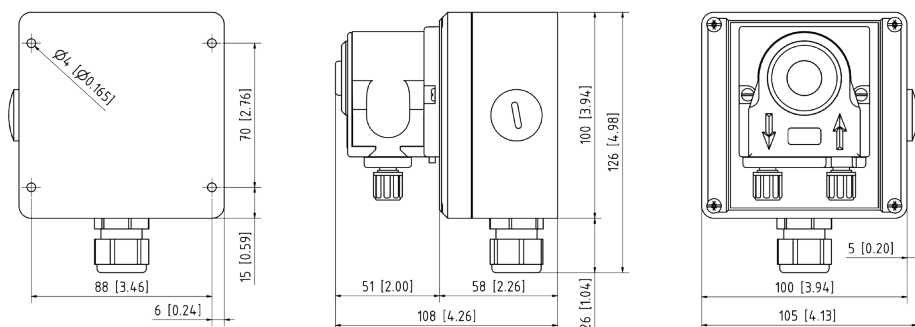

Dimensions in mm [Inches]

Metric dimensions are rounded. Inch dimensions are for reference only. In case of doubt or conflict, metric units take priority.

Technical Data

Peristaltic pump Series SR25*	Version SR25.2/3/6	Version SR25.2/3/6-G	Version SR25.2/3/6-W
Part No.	SR25.2 01P1300 SR25.3 01P1310 SR25.6 01P1350	SR25.2-G 01P1120 SR25.3-G 01P1110 SR25.6-G 01P1400	SR25.2-W 01P1307 SR25.3-W 01P1320 SR25.6-W 01P1360
Housing	No	Yes; material: polycarbonate (PC)	No
Method of mounting	Attached to a front plate	Wall-mounting	Inside or attached to an enclosure
Protection/electrical standard	IP10 EN 60529	IP52 EN 60529	IP10 EN 60529
Electrical connection	Terminal 1.5 mm ²	Terminal 1.5 mm ² , 1 x M20 x 1.5	Terminal 1.5 mm ²
Dimensions in mm [Inches] [H x W x D]	64 x 84 x 52 plus 40 for the motor [≈ 2.50" x 3.31" x 2.04" plus 1.56"]	126 x 105 x 108 [≈ 4.98" x 4.13" x 4.26"]	80 x 107 x 94 [≈ 3.2" x 4.2" x 3.7"]
Weight in kg [lbs]	0.4 [≈ 0.88 lbs]	0.6 [≈ 1.3 lbs]	0.5 [≈ 1.10 lbs]
Suction max.	200 mbar abs.		
Pressure max.	2200 mbar abs.		
Sample temperature	0 to +60 °C [32 to 140 °F]		
Ambient temperature	0 to +50 °C [32 to 122 °F]		
Storage temperature	-10 to +60 °C [14 to 140 °F]		
Material of sample-contacting parts	PVDF, Novoprene		
Power supply/consumption	115/230 V, 50/60 Hz/5 VA		
Continuous duty	100 % ED		
Medium connections (gas connections) made of PVDF	Tube connections DN 4/6 (standard) Tube support 4 Tube connection 6/8 Tube connection 1/4"		

Material of sample-contacting parts (tubing)

Novoprene® (standard) used for water, weak acids or bases

Masterflex® (reinforced contact springs necessary!) used for strong acids or bases, carbon disulfide, toluene, gasoline; alcohols

Chemzure® used for methylethyl ketone, acetone, tetrahydrofuran

Selection for Novoprene tubing (standard)

Peristaltic pump version	SR25.3-G/W	SR25.2-G/W	SR25.6-G/W
Rotational speed (revolutions per minute)	1 rpm	5 rpm	10 rpm
Pumping capacity	Tubing Ø 1.6 mm ID	0.012 l/h (standard)	0.12 l/h
	Tubing Ø 3.2 mm ID	0.05 l/h	0.3 l/h (standard)
	Tubing Ø 4.8 mm ID	0.08 l/h	0.4 l/h
			0.8 l/h (standard)

Other tubing materials and sizes on request.

Chemraz® is a registered trademark for perfluoroelastomer by Greene Tweed, USA.

Masterflex® is a registered trademark for tubes of Masterflex Group, Germany.